

KUTTING-EDGE.

Pathway Edger for TORO® Workman

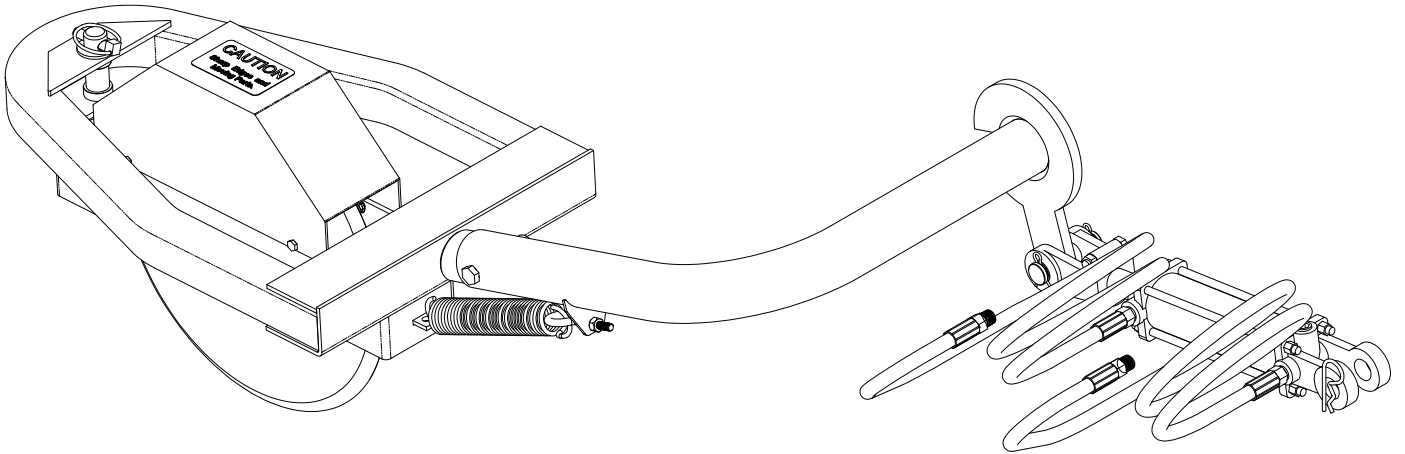

Bishop Enterprises, Inc.

9033 Shelbyville Hwy. Bell Buckle, TN 37020

Tel: 615.793.6052 Fax: 615.793.9525

Look For Other Great BEI Products On The Web at

www.turf-aire.com

Kutting Edge Mounting Instructions

Mounting plate:

The mounting plate for the Kutting Edge is to be mounted to the frame on the left side of the Workman® between the front wheel and the oil cooler using the existing bolts. Remove the bolts prior to installation of the mounting plate. See the mounting plate illustration for the location of the mounting holes. Tighten the bolts – securing the mounting plate.

Main Control Arm:

Attach the edger arm to the side of the mounting plate by sliding the flanged end of the edger arm over the stationary shaft welded to the side mounting plate. Locate the notch on the flange end of the edger arm and line up with the welded retainer bracket. Rotate arm while sliding the arm onto the stationary shaft. Once the unit is behind the welded retaining bracket, lower the edger arm towards the front of the truck.

Hydraulic Cylinder with Hoses:

Attach the stationary end of the hydraulic cylinder to the mounting pin on the front of the mounting plate. Secure the hydraulic cylinder to the mounting pin by inserting the hair pin. Next, attach the dynamic end of the hydraulic cylinder to the tab on the flanged end of the edger arm. Secure with one (1) cylinder pin and two (2) quick pins. Route the hydraulic hoses to the back of the TORO® Workman® to the couplers and secure using the enclosed cable ties. Connect via quick couplers. Caution: Avoid contact of hydraulic hoses with the muffler system AS HOSES MAY RUPTURE.

Main Coultter Frame:

Locate the Main Coultter Frame that will be installed to the other end of the Main Control Arm. This will be “V-shaped” with a tube coming from one end. Insert the tube into the open end of the Main Control Arm. Line up the holes located on the Main Coultter Frame and on the Main Control Arm. Secure the Main Coultter Frame to the Main Cotrol Arm using the 1/2” bolt, nut and lockwasher provided.

Coultter Carrier Frame:

Next, mount the Coultter Carrier Frame containing the Coultter Wheel and hub to the Main Coultter Frame by inserting the pivot post on the Coultter Carrier Frame into the bushings located on the Main Coultter Frame. Secure the Coultter Carrier Frame using the lynch pin. Caution: TO AVOID INJURY, USE SPECIAL CARE TO AVOID CONTACT WITH THE COULTER DISC'S SHARP EDGES. See page 3 and 4 to identify all components.

Figure #1

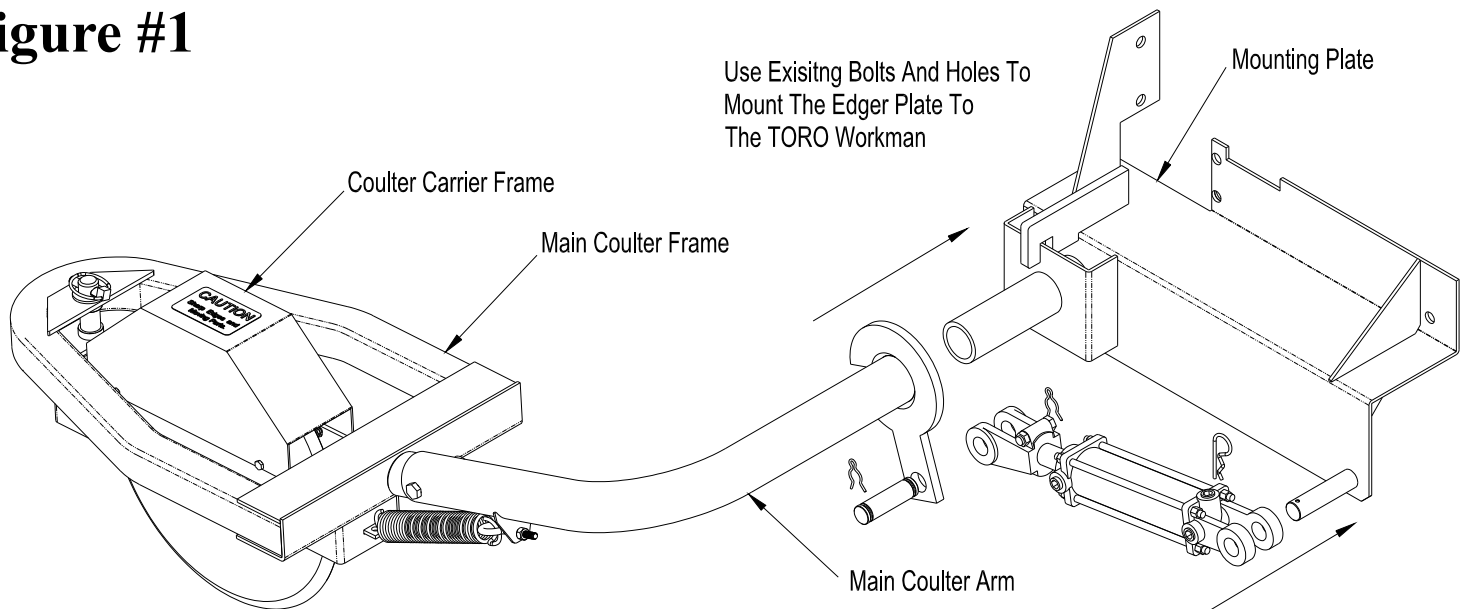

Parts List For "Cutting Edge" Edger

Item #	Qty.	Part #	Description
1	1	e10018N	Main Control Arm
2	1	e10061	1/2-13 x 3" Hx Hd Bolt
3	2	e10043	3/8-16 Hx Nut
4	1	e10042	3/8-16 x 3" Eyebolt
5	1	e10037	Spring
6	3	e10014D	1/2-13 Hx Nut
7	2	e10038	1/2" Carrier Bearing
8	2	e10060	Spacer
9	1	e10033N	Coulter Guard
10	1	e10026	Coulter Hub
10-A	1	e10026F	Coulter Hub With Bearing
11	1	e10013	Disc
12	4	e10026B	3/8-16 x 1-1/4" Bolt
13	2	e10014B	1/2" Flat Washer
14	1	e10014	1/2-13 x 5-1/2" Mounting Bolt
15	1	e10026A	Coulter Bearing
16	4	e10026D	3/8-16 Hx Nut
17	1	e10014E	1/2"x 1" Spacer
18	2	e10014C	1/2" Lock Washer
19	1	e10022A	Coulter Carrier Frame
20	2	e10039	Bushing
21	4	e10034B	1/4-20 x 1/2" Hx Hd Bolt
22	4	e95001	1/4-20 Hx Nut
23	1	e10025A	Main Coulter Frame
24	1	e10040	Lynch Pin
25	1	e10062	Caution Decal
26	1	e10016	#10 Hairpin
27	1	e10019	Hydraulic Cylinder
28	2	e10030T	98" Hydraulic Hose
29	2	e10031	Male Quick Connect Adapter Prior 2004
29A	1	e10031T1	Male Quick Connect New Toro 2004
29B	1	e10032T1	Females Quick Connect New Toro 2004
30	2	e10021	1" Hairpin Clip For Pin
31	1	e10020	1" Cylinder Mounting Pin
32	1	e10012T	Side Mounting Plate



Bishop Enterprises, Inc.

9033 Shelbyville Hwy. Bell Buckle, TN 37020
Tel: 615.793.6052 Fax: 615.793.9525

Look For Other Great BEI Products On The Web at
www.turf-aire.com

Illustrated Parts List For Kitting Edge on TORO Workman

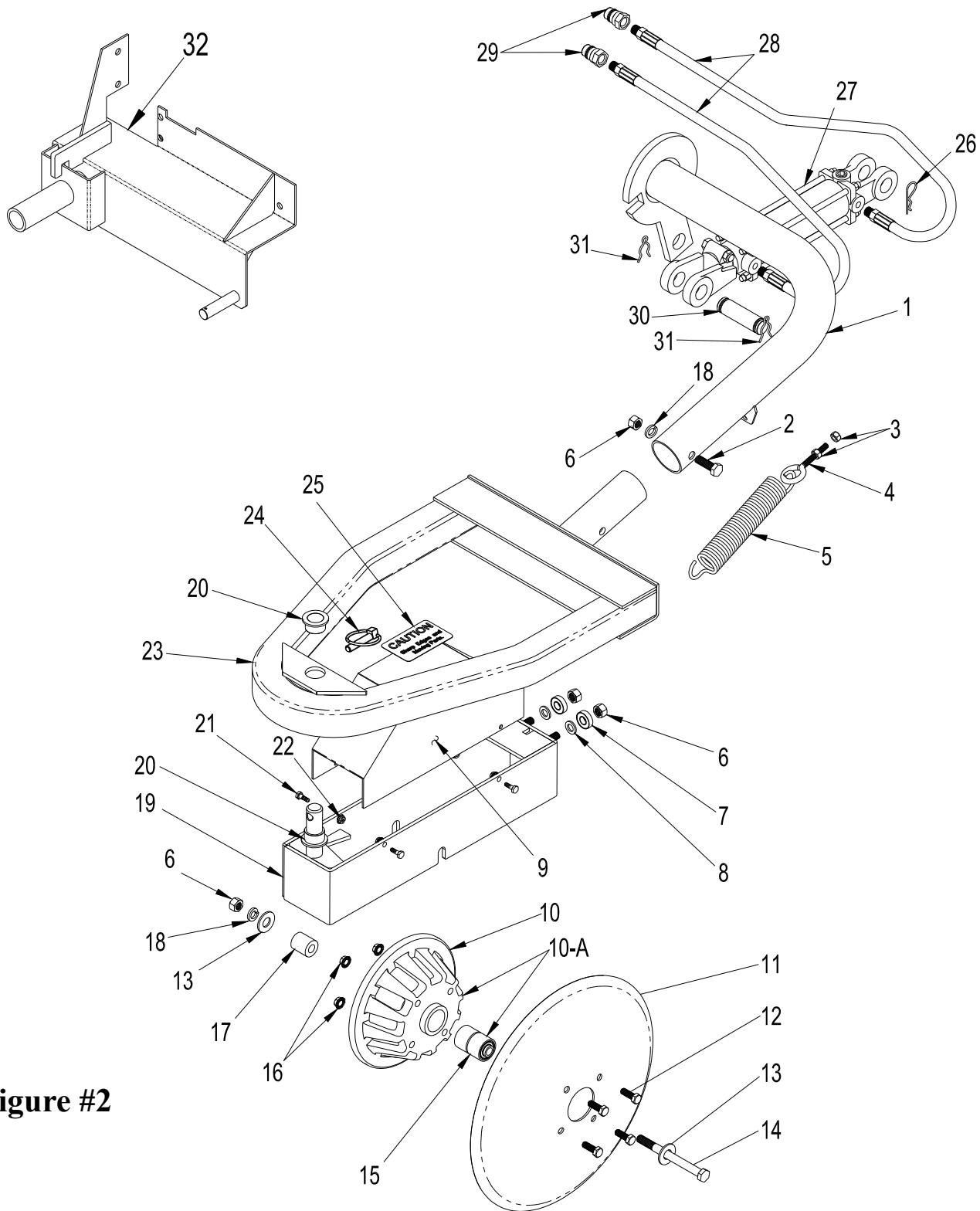

Note: On Toro v
2004, item numbe
connectors e1003
2004 and later, it
29A Male Quick
29B Female Quick

Figure #2